

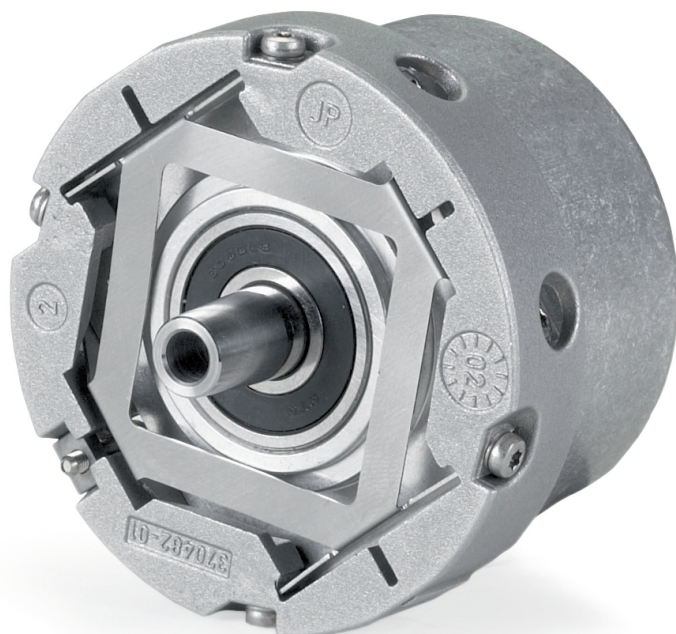

HEIDENHAIN



Product Information

ECN 1313
EQN 1325
ECN 1325
EQN 1337

Absolute Rotary Encoders
with Tapered Shaft

ID 768295-xx
ID 1178020-xx
ID 827039-xx
ID 1178019-xx
ID 1353127-xx
ID 1353128-xx
ID 1353130-xx

08/2023

ECN/EQN 1300 series

Absolute rotary encoders

- 06 stator coupling for axial mounting
- 65B tapered shaft

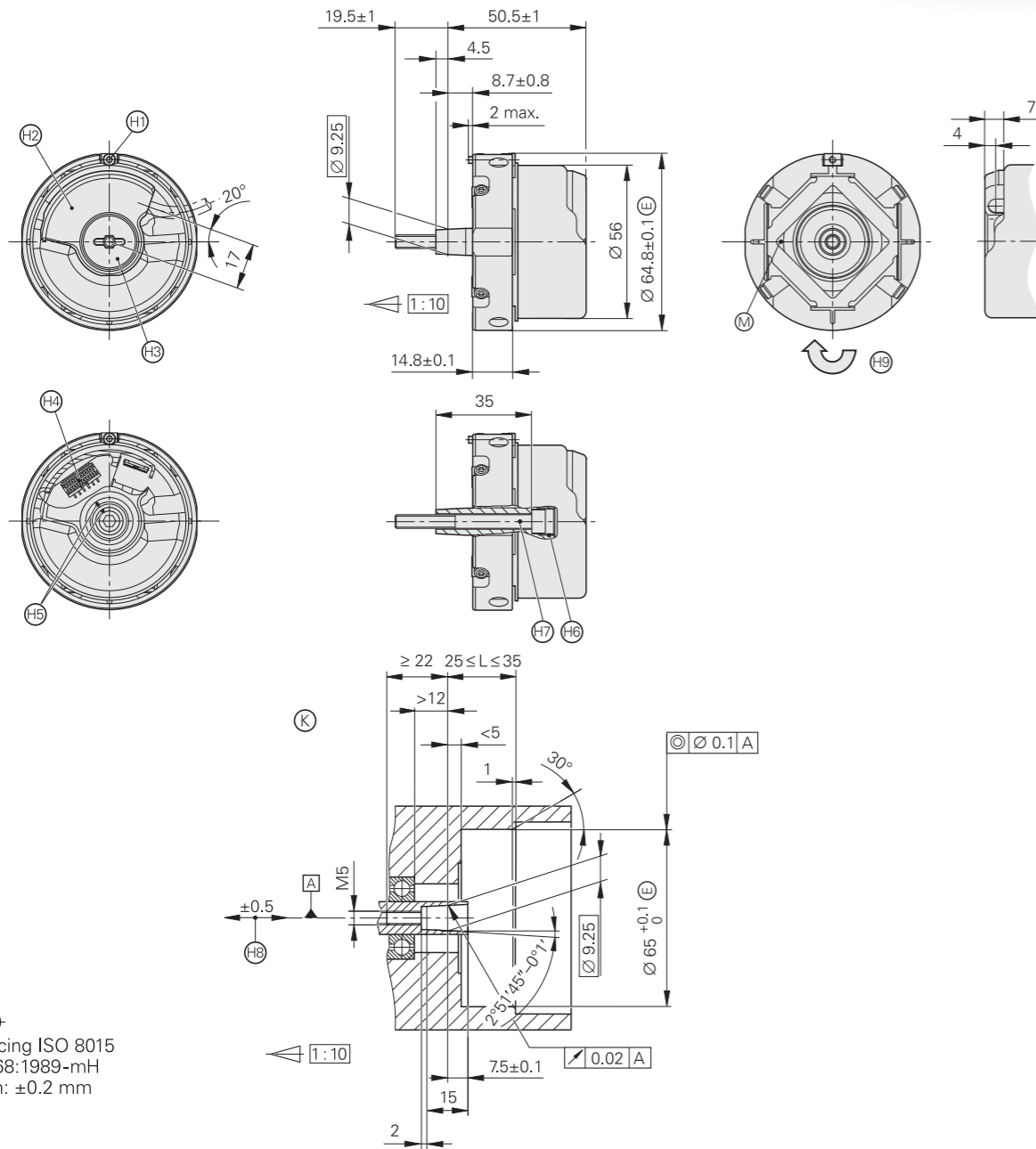
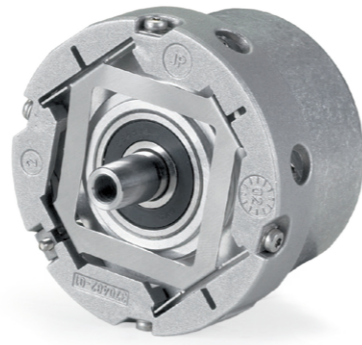

- = Bearing of mating shaft
- ⊙ = Required mating dimensions
- ⊙ = Measuring point for operating temperature
- 1 = Clamping screw for coupling ring; width A/F 2
- 2 = Die-cast cover
- 3 = Screw plug; widths A/F 3 and 4
- 4 = ECN/EQN: 12-pin PCB connector
ECN/EQN: 12-pin + 4-pin PCB connector
- 5 = ECN/EQN: zero position of shaft and housing
- 6 = M10 back-off thread
- 7 = Self-locking screw: DIN 6912 – M5x50 – 08.8 SW4
- 8 = Compensation of mounting tolerances and thermal expansion; no dynamic movement permitted
- 9 = Direction of shaft rotation for ascending position values

	Absolute			
	ECN 1313	ECN 1325	EQN 1325	EQN 1337
Interface	EnDat 2.2			
Ordering designation	EnDat01	EnDat22	EnDat01	EnDat22
Position values per revolution	8192 (13 bits)	33554432 (25 bits)	8192 (13 bits)	33554432 (25 bits)
Revolutions	–			4096 (12 bits)
Elec. permiss. speed/ deviations ²⁾	512 lines: 5000 rpm/±1 LSB 12000 rpm/±100 LSB 2048 lines: 1500 rpm/±1 LSB 12000 rpm/±50 LSB	15000 rpm (for continuous position values)	512 lines: 5000 rpm/±1 LSB 12000 rpm/±100 LSB 2048 lines: 1500 rpm/±1 LSB 12000 rpm/±50 LSB	15000 rpm (for continuous position values)
Calculation time t_{cal} Clock frequency	≤ 9 μs ≤ 2 MHz	≤ 7 μs ≤ 8 MHz	≤ 9 μs ≤ 2 MHz	≤ 7 μs ≤ 8 MHz
Incremental signals	~ 1 V _{PP} ¹⁾	–	~ 1 V _{PP} ¹⁾	–
Line count*	512 2048	2048	512 2048	2048
Cutoff frequency –3 dB	2048 lines: ≥ 400 kHz 512 lines: ≥ 130 kHz	–	2048 lines: ≥ 400 kHz 512 lines: ≥ 130 kHz	–
System accuracy	512 lines: ±60"; 2048 lines: ±20"			
Electrical connection	12-pin	16-pin with connection for temp. sensor ³⁾	12-pin	16-pin with connection for temp. sensor ³⁾
Supply voltage	DC 3.6 V to 14 V			
Power consumption (maximum)	3.6 V: ≤ 0.6 W 14 V: ≤ 0.7 W		3.6 V: ≤ 0.7 W 14 V: ≤ 0.8 W	
Current consumption (typical)	5 V: 85 mA (without load)		5 V: 105 mA (without load)	
Shaft	Tapered shaft Ø (9.25 mm); taper: 1:10			
Mech. permiss. speed n	≤ 15000 rpm		≤ 12000 rpm	
Starting torque (typical)	0.01 Nm (at 20 °C)			
Moment of inertia of rotor	2.6 · 10 ⁻⁶ kgm ²			
Natural frequency f_N (typical)	1800 Hz			
Permissible axial motion of measured shaft	±0.5 mm			
Vibration 55 Hz to 2000 Hz Shock 6 ms	≤ 300 m/s ² ⁴⁾ (EN 60068-2-6); 10 Hz to 55 Hz constant over 4.9 mm peak to peak ≤ 2000 m/s ² (EN 60068-2-27)			
Operating temperature	–40 °C to 115 °C			
Relative humidity	≤ 93% (40 °C/21 d as per EN 60068-2-78); condensation excluded			
Protection rating EN 60529	IP40 when mounted			
Mass	≈ 0.25 kg			
ID number	768295-03/-11 768295-51 ⁵⁾ /-53 ⁵⁾	1178019-01 1178019-51 ⁵⁾	827039-04/-06 827039-51 ⁵⁾ /-55 ⁵⁾	1178020-01 1178020-51 ⁵⁾

* Please select when ordering

- 1) Deviating tolerances Signal amplitude: 0.8 V_{PP} to 1.2 V_{PP}
Asymmetry: 0.05
Amplitude ratio: 0.9 to 1.1
Phase angle: 90° elec. ±5° elec.
Signal-to-noise ratio E, F: ≥ 100 mV
- 2) Speed-dependent deviations between absolute and incremental signals

³⁾ Evaluation optimized for KTY 84-130

- ⁴⁾ Valid in accordance with standard at room temperature; at operating temperatures of up to 100 °C: ≤ 300 m/s²; up to 115 °C: ≤ 150 m/s² (≥ 100 °C: 10 Hz to 55 Hz constant over 2.45 mm peak to peak)
- ⁵⁾ In collective package upon request

	Absolute	
	ECN 1313	EQN 1325
Interface	SSI	
Ordering designation	SSI01r1	SSI07r1
Position values per revolution	8192 (13 bits)	
Revolutions	–	4096 (12 bits)
Electrically permissible speed/error ²⁾	15000 rpm/±12 LSB	
Calculation time t_{cal}	≤ 5 μs	
Incremental signals	~ 1 V _{PP} ¹⁾	
Line count*	512 2048	
Cutoff frequency –3 dB	≥ 500 kHz	
System accuracy	512 lines: ±60"; 2048 lines: ±20"	
Electrical connection	16-pin (12+4) PCB connector	
Supply voltage	4.75 V to 30 V DC	
Power consumption (max.)	4.75 V: ≤ 600 mW 30 V: ≤ 775 mW	4.75 V: ≤ 675 mW 30 V: ≤ 875 mW
Current consumption (typical)	5 V: 70 mA (without load)	5 V: 85 mA (without load)
Shaft	Tapered shaft Ø (9.25 mm); taper: 1:10	
Mech. permiss. shaft speed n	≤ 15000 rpm	≤ 12000 rpm
Starting torque (typical)	0.01 Nm (at 20 °C)	
Moment of inertia of rotor	2.6 · 10 ⁻⁶ kgm ²	
Natural frequency f_N (typical)	1800 Hz	
Permissible axial motion of measured shaft	±0.5 mm	
Vibration 55 Hz to 2000 Hz Shock 6 ms	≤ 300 m/s ² ³⁾ (EN 60068-2-6); 10 Hz to 55 Hz constant over 4.9 mm peak to peak ≤ 2000 m/s ² (EN 60068-2-27)	
Operating temperature	–40 °C to 115 °C	
Relative humidity	≤ 93% (40 °C/21 d as per EN 60068-2-78); condensation excluded	
Protection rating EN 60529	IP40 when mounted	
Mass	≈ 0.25 kg	
ID number	1353127-02/-07 ⁴⁾ 1353128-01/-06 1353128-03 ⁵⁾	1353130-01/-03

* Please select when ordering

1) Deviating tolerances Signal amplitude: 0.8 V_{PP} to 1.2 V_{PP}
Asymmetry: 0.05
Amplitude ratio: 0.9 to 1.1
Phase angle: 90° elec. ±5° elec.

2) Speed-dependent deviations between absolute and incremental signals

3) Valid in accordance with standard at room temperature; at operating temperatures of
up to 100 °C: ≤ 300 m/s²;
up to 115 °C: ≤ 150 m/s² (≥ 100 °C: 10 Hz to 55 Hz constant over 2.45 mm peak to peak)

4) Encoder with hybrid bearing

5) In collective package upon request

Mounting

The tapered shaft of the rotary encoder is pressed onto the measured shaft and fastened with a central screw. The stator coupling is clamped by means of an axially tightenable screw in a location hole.

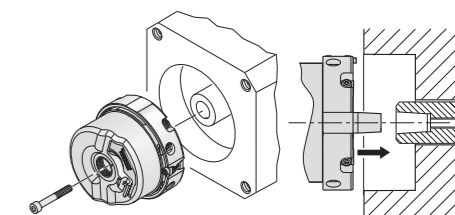

Mounting accessories

Mounting aid

To avoid damage to the cable, use the mounting aid to connect and disconnect the cable assembly. The pulling force must be applied solely to the connector and not to the wires.

ID 1075573-01

For more mounting information and mounting aids, see the **Mounting Instructions** and the **Encoders for Servo Drives** brochure. The mounting quality can be inspected with the **PWM 21** and **ATS** software.



Interface

SSI position values

The **position value** is transmitted, starting with the most significant bit (MSB), over the data lines (DATA) in synchronism with a clock signal (CLOCK) provided by the control. The SSI-standard data word length for singleturn encoders is 13 bits, and for multiturn encoders, 25 bits. In addition to the absolute position values, **incremental signals** can also be transmitted. For a description of the signals, see 1 V_{PP} incremental signals in the *Rotary Encoders* brochure.

The following **functions** cannot be activated via programming inputs:

- **Direction of rotation**
- **Zero reset** (setting to zero)

Data transmission



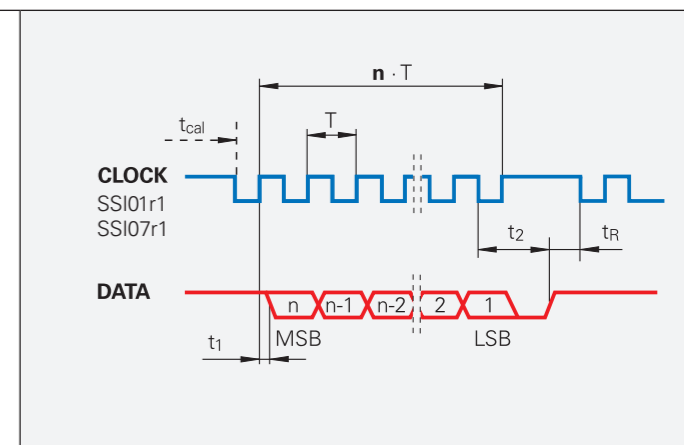

$T = 1$ to $10 \mu\text{s}$
 t_{cal} See the specifications
 $t_1 \leq 0.4 \mu\text{s}$ (without cable)
 $t_2 = 17$ to $20 \mu\text{s}$
 $t_R \geq 5 \mu\text{s}$
 n = Data word length
13 bits for ECN/ROC
25 bits for EQN/ROQ

CLOCK and DATA not shown

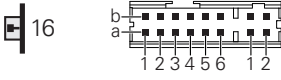

Electrical connection

Pin layout SSI01r1 / SSI07r1





16-pin (12 + 4) PCB connector														
														
	Power supply					Incremental signals				Serial data transmission				
	12+4	1b	6a	4b	3a	/	2a	5b	4a	3b	6b	1a	2b	5a
		U _P	Sensor U _P	0V	Sensor 0V	Internal shield	A+	A-	B+	B-	DATA	DATA	CLOCK	CLOCK
														

Cable shield connected to housing; **U_P** = Power supply voltage

Sensor: The sense line is connected in the encoder with the corresponding power line.

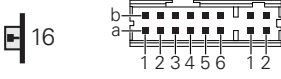
Vacant pins or wires must not be used!

EnDat22 pin layout

16-pin PCB connector											
											
	Power supply					Serial data transmission				Other signals ¹⁾	
	12+4	1b	6a	4b	3a	6b	1a	2b	5a	1a	1b
		U _P	Sensor U _P	0V	Sensor 0V	DATA	DATA	CLOCK	CLOCK	T ⁺ ²⁾	T ⁻ ²⁾
											

¹⁾ Only for adapter cables inside the motor housing

²⁾ Connections for external temperature sensor; evaluation optimized for KTY 84-130





(see *Temperature measurement in motors* in the *Encoders for Servo Drives* brochure)

Cable shield connected with housing; **U_P** = Power supply voltage; **T** = Temperature

Sensor: The sense line is connected in the encoder with the corresponding power line.

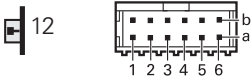
Vacant pins or wires must not be used!

EnDat01 pin layout

12-pin PCB connector														
														
	Power supply					Incremental signals				Serial data transmission				
	12	1b	6a	4b	3a	/	2a	5b	4a	3b	6b	1a	2b	5a
		U _P	Sensor U _P	0V	Sensor 0V	Internal shield	A+	A-	B+	B-	DATA	DATA	CLOCK	CLOCK
														

Cable shield connected with housing; **U_P** = Power supply voltage; **T** = Temperature

Sensor: The sense line is connected in the encoder with the corresponding power line.

Vacant pins or wires must not be used!

HEIDENHAIN

DR. JOHANNES HEIDENHAIN GmbH

Dr.-Johannes-Heidenhain-Straße 5

83301 Traunreut, Germany

☎ +49 8669 31-0

FAX +49 8669 32-5061

info@heidenhain.de

www.heidenhain.com

This Product Information document supersedes all previous editions, which thereby become invalid. The basis for ordering from HEIDENHAIN is always the Product Information document edition valid when the order is placed.



Further information:

Comply with the requirements described in the following documents to ensure correct and intended operation:

- Operating Instructions

1403368