



# HEIDENHAIN



**Functional  
Safety**

Product Information

## **ECN 1123 S** **EQN 1135 S**

Absolute Rotary Encoders  
with DRIVE-CLiQ Interface for  
Safety-Related Applications

Firmware 53

# ECN 1123S, EQN 1135S

Rotary encoders for absolute position values with safe singleturn information

- 75A mounted stator coupling
- Blind hollow shaft (Ø 6 mm) for axial clamping (1KA)

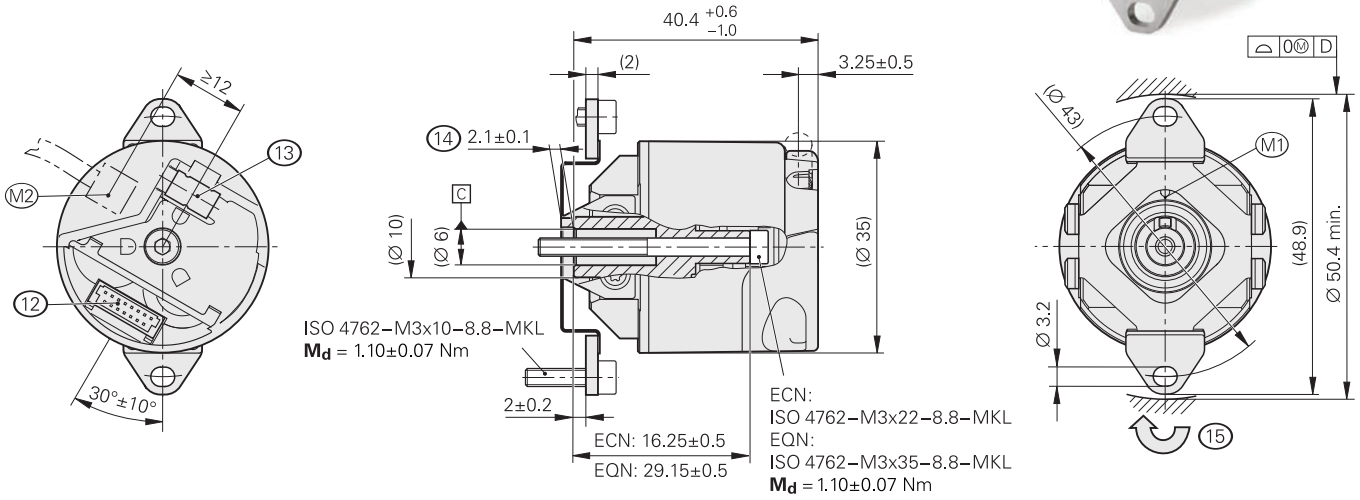

## Required mating dimensions

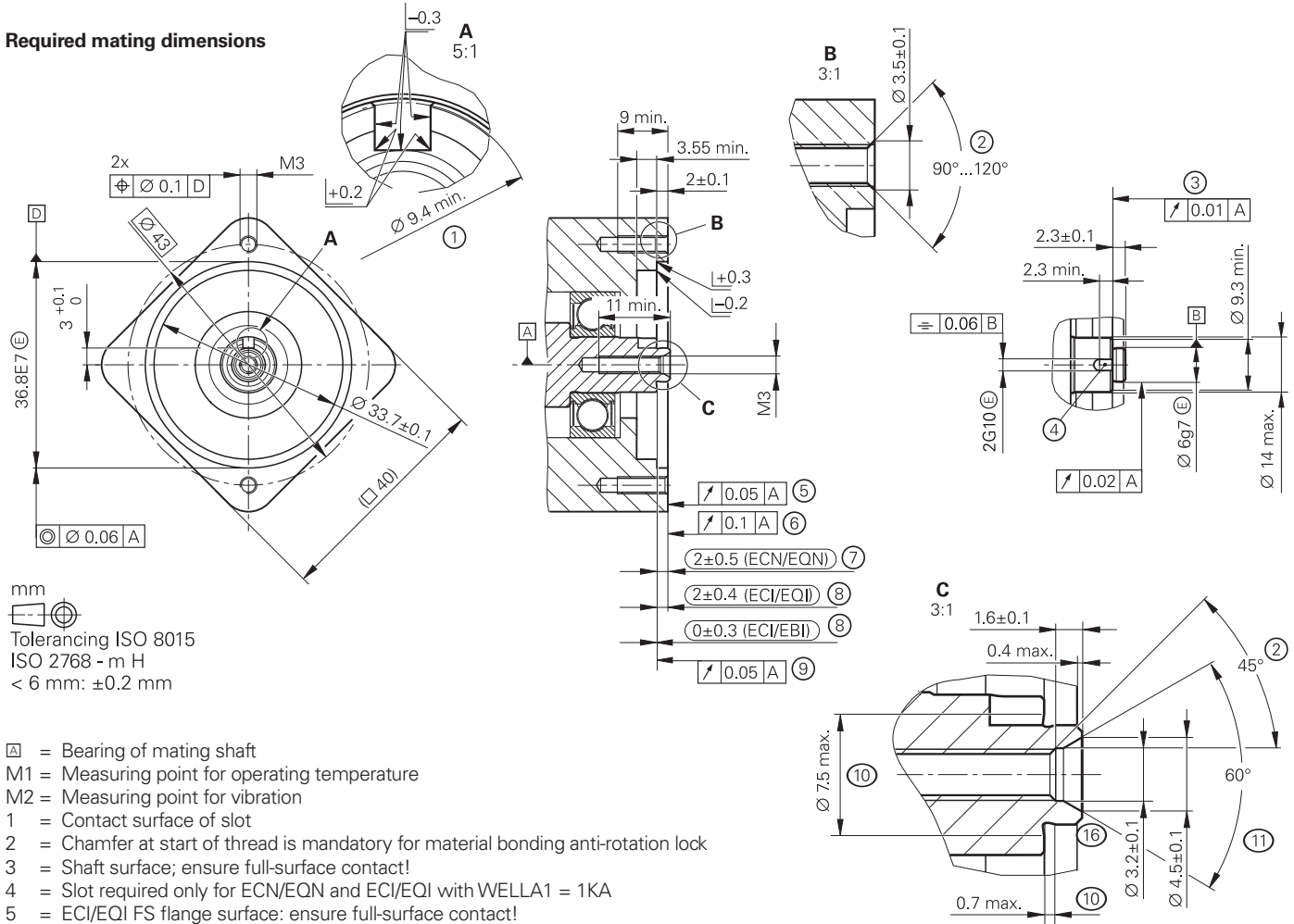

- = Bearing of mating shaft
- M1 = Measuring point for operating temperature
- M2 = Measuring point for vibration
- 1 = Contact surface of slot
- 2 = Chamfer at start of thread is mandatory for material bonding anti-rotation lock
- 3 = Shaft surface; ensure full-surface contact!
- 4 = Slot required only for ECN/EQN and ECI/EQI with WELLA1 = 1KA
- 5 = ECI/EQI FS flange surface; ensure full-surface contact!
- 6 = Coupling surface of ECN/EQN
- 7 = Maximum permissible deviation between the shaft surface and coupling surface; compensation of mounting tolerances and thermal expansion, of which  $\pm 0.15 \text{ mm}$  of dynamic axial motion is permitted
- 8 = Maximum permissible deviation between the shaft surface and flange surface; compensation of mounting tolerances and thermal expansion
- 9 = ECI/EBI flange surface; ensure full-surface contact!
- 10 = Undercut
- 11 = Possible centering hole
- 12 = 15-pin PCB connector
- 13 = Cable fastener with crimp sleeve; diameter:  $4.3 \text{ mm} \pm 0.1 \text{ mm}$ ; length:  $7 \text{ mm}$
- 14 = Positive locking element; ensure correct engagement in Slot 4 (e.g., by measuring the device overhang)
- 15 = Direction of shaft rotation for ascending position values
- 16 = Uncoated; shaft coating not permitted

Specifications	ECN 1123S singletum	EQN 1135S multitum
<b>Functional safety</b> for applications with up to	As a single-encoder system for monitoring functions and closed-loop functions <ul style="list-style-type: none"> <li>• SIL 2 as per EN 61508 (further basis for testing: EN 61800-5-2)</li> <li>• Category 3, PL d as per EN ISO 13849-1:2015</li> </ul> Safe in singletum operation	
PFH <sup>1)</sup>	$\leq 27 \cdot 10^{-9}$ (probability of dangerous failure per hour)	
Safe position <sup>2)</sup>	<i>Encoder</i> : $\pm 1.76^\circ$ (safety-related measuring step SM = $0.7^\circ$ ) <i>Mechanical coupling</i> : $\pm 2^\circ$ (fault exclusion for the loosening of the shaft coupling and stator coupling, designed for accelerations $\leq 300 \text{ m/s}^2$ )	
<b>Interface/ordering designation</b>	DRIVE-CLiQ / DQ01	
Firmware	01.32.26.53	
Siemens software <sup>3)</sup> Firmware 01.32.26.53	SINAMICS, SIMOTION: $\geq \text{V4.4 HF4}$ ; SINUMERIK with safety: $\geq \text{V4.4 SP2}$ ; SINUMERIK without safety: $\geq \text{V4.4 SP1 HF3}$	
Position values per revolution	8388608 (23 bits)	
Revolutions	–	4096 (12 bits)
Calc. time TIME_MAX_ACTVAL <sup>4)</sup>	$\leq 8 \mu\text{s}$	
<b>System accuracy</b>	$\pm 60''$	
<b>Electrical connection</b>	15-pin PCB connector (with connection for external temperature sensor <sup>5)</sup> )	
Cable length	$\leq 40 \text{ m}$ (see <i>Cable lengths</i> in the <i>Cables and Connectors</i> brochure)	
Supply voltage	DC 24 V (10 V to 28.8 V); up to DC 36.0 V possible without compromising functional safety	
Power consumption (max.)	At 10 V: $\leq 850 \text{ mW}$ ; at 28.8 V: $\leq 900 \text{ mW}$	At 10 V: $\leq 950 \text{ mW}$ ; at 28.8 V: $\leq 1000 \text{ mW}$
Current consumption (typical)	At 24 V: 32 mA (without load)	At 24 V: 35 mA (without load)
<b>Shaft</b>	Blind hollow shaft ( $\varnothing 6 \text{ mm}$ ) with positive-locking element (1KA)	
Speed <sup>6)</sup>	$\leq 12000 \text{ rpm}$	
Starting torque (typical)	0.001 Nm (at 20 °C)	0.002 Nm (at 20 °C)
Moment of inertia of rotor	$0.4 \cdot 10^{-6} \text{ kgm}^2$	
Angular acceleration of rotor	$\leq 1.0 \cdot 10^5 \text{ rad/s}^2$	
Axial motion of measured shaft	$\leq \pm 0.5 \text{ mm}$	
<b>Natural frequency</b> of stator coupling	$\geq 1000 \text{ Hz}$	
<b>Vibration</b> 55 Hz to 2000 Hz <b>Shock</b> 6 ms	$\leq 200 \text{ m/s}^2$ (EN 60068-2-6); 10 Hz to 55 Hz, 3.2 mm constant peak to peak $\leq 2000 \text{ m/s}^2$ (EN 60068-2-27)	
<b>Operating temperature</b>	$-40 \text{ }^\circ\text{C}$ to $95 \text{ }^\circ\text{C}$	
<b>Trigger threshold</b> for exceeded temperature error message	125 °C (measurement accuracy of the internal temperature sensor: $\pm 7 \text{ K}$ at 125 °C)	
<b>Relative humidity</b>	$\leq 93 \%$ (40 °C/21 d as per EN 60068-2-78), without condensation	
<b>Protection</b> EN 60529	IP40 (read about insulation under <i>Electrical safety</i> in the <i>Interfaces of HEIDENHAIN Encoders</i> brochure; contamination from the ingress of liquid must be prevented)	
<b>Mass</b>	$\approx 0.1 \text{ kg}$	
<b>ID number</b>	1211015-02	1211017-02

<sup>1)</sup> For use at:  $\leq 1000 \text{ m}$  above sea level

<sup>2)</sup> Further tolerances may arise in subsequent electronics after position value comparison (contact mfr. of subsequent electronics)

<sup>3)</sup> Information from Siemens as per the document "Certified encoders with DRIVE-CLiQ Dependencies on SIMOTION / SINUMERIK and SINAMICS Hardware and Software versions" (version: 12/2018)

<sup>4)</sup> The calculation time TIME\_MAX\_ACTVAL specifies the time after which a data transfer from the encoder to the control can start within the current-regulator clock time.

<sup>5)</sup> See *Temperature measurement in motors* in the *Encoders for Servo Drives* brochure.

<sup>6)</sup> At  $\geq 2$  position requests per revolution

# Mounting

The blind hollow shaft of the rotary encoder is seated onto the measured shaft and fastened with a central screw. It is particularly important to ensure that the positive-locking element of the rotary encoder shaft securely engages the corresponding slot in the measured shaft. Mounting on the stator side is performed without a centering collar on a flat surface with two clamping screws. Use screws with material bonding anti-rotation lock (see *Mounting accessories*).

For the customer-side mounting design, the material properties and conditions in accordance with the *General mechanical information* in the *Encoders for Servo Drives* brochure must be complied with. The materials specifications for aluminum and steel apply both to the customer-side shaft and stator.

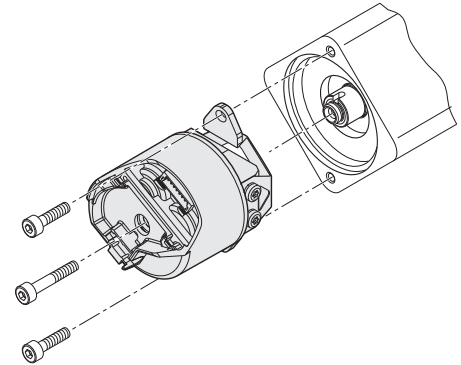

For the design of the mechanical fault exclusion for the shaft connection, the following maximum torque  $M_{max}$  must be taken into account:

$$M_{max} = 1.0 \text{ Nm}$$

The customer's mechanical design must ensure that the maximum torque  $M_{max}$  occurring in the application can be transmitted.

## Mounting accessories

### Screws

Screws (central screw, mounting screws) are not included in delivery and can be ordered separately.

	Screws <sup>1)</sup>		Quantity
<b>Central screw for ECN 1123</b>	ISO 4762-M3×22-8.8-MKL	ID 202264-65	10 or 100
<b>Central screw for EQN 1135</b>	ISO 4762-M3×35-8.8-MKL	ID 202264-66	
<b>Fastening screw for flange</b>	ISO 4762-M3×10-8.8-MKL	ID 202264-87	20 or 200

<sup>1)</sup> With coating for material bonding anti-rotation lock

Please note the information on screws from HEIDENHAIN in the *Encoders for Servo Drives* brochure, under *Screws with material bonding anti-rotation lock* in the chapter *General mechanical information*.

### Mounting aid

To avoid damage to the cable, use the mounting aid to connect and disconnect the cable assembly. The pulling force must be applied only to the connector and not to the wires.

ID 1075573-01



### Mounting aid

The mounting aid allows the shaft of the rotary encoder to be turned from the rear of the device, making it easy to find the positive-locking connection between the encoder shaft and the measured shaft.

ID 821017-03



# Integrated temperature evaluation

These rotary encoders feature a temperature sensor integrated into the encoder electronics and an evaluation circuit for an external temperature sensor. In both cases, the respective digitized temperature value is transmitted purely serially via the DRIVE-CLiQ interface. Please bear in mind that neither the temperature measurement nor the transmission of the temperature value is safe in terms of functional safety.

The temperature measured by the internal temperature sensor is higher by a device-specific and application-specific amount than the temperature at measuring point M1, as shown in the dimension drawing.

Upon reaching a trigger threshold for the internal temperature sensor, these rotary encoders issue an "Alarm 405" error message. This threshold may vary depending on the encoder model and is stated in the specifications. During operation, it is recommended that the temperature be kept adequately below this threshold.

Fulfillment of the encoder's intended use requires adherence to the operating temperature at measuring point M1.

The internal temperature sensor has an accuracy of  $\pm 7$  K.

## Temperature measurement in motors

To protect a motor from overloading, the motor manufacturer usually installs a temperature sensor in close proximity to the motor winding.

The PT 1000 or, for example, the KTY 84-130 semiconductor sensor is to be used. For a PT 1000, the following values apply with regard to the accuracy of the evaluation circuit:

$\pm 4$  K at 80 °C to 160 °C  
 $\pm 6$  K at -40 °C to 80 °C  
 $\pm 6$  K at 160 °C to 200 °C

For a KTY 84-130 semiconductor sensor, the following values apply with regard to the accuracy of the evaluation circuit:

$\pm 2$  K at 80 °C to 160 °C  
 $\pm 6$  K at -40 °C to 80 °C  
 $\pm 6$  K at 160 °C to 200 °C

The temperature values are transmitted via the DRIVE-CLiQ protocol.

The temperature sensor used is adjustable via Parameter 601 in the configuration software (e.g., Starter software) of the drive.

# Online diagnostics and firmware version

## **Online diagnostics**

For evaluation of the encoder's functionality, valuation numbers can be cyclically read from the encoder. These valuation numbers reflect the current status of the encoder and can be used to determine its function reserves. The function reserves are also transmitted via the DRIVE-CLiQ interface and can be displayed in the higher-level control.

Further information is available from HEIDENHAIN upon request.

## **Firmware version**

The firmware version can be read out over the DRIVE-CLiQ parameter "Act\_FW\_Version" (index 0). The final two digits of the displayed value are decisive.

# Electrical connection



## Cables

<b>EPG encoder cable inside the motor</b> $\varnothing 3.7 \text{ mm}$ ; $2 \times (2 \times 0.06 \text{ mm}^2) + 4 \times 0.06 \text{ mm}^2$ ; $A_P = 0.06 \text{ mm}^2$ With shield crimping ( $\varnothing 4.3 \text{ mm}$ ) and wires for a temperature sensor <sup>1)</sup> TPE $2 \times 0.16 \text{ mm}^2$		
With 15-pin PCB connector and 8-pin LK28 M12 flange socket (male) <sup>2)</sup>		ID 1217143-xx

<sup>1)</sup> Electromagnetic compatibility must be ensured in the complete system.

<sup>2)</sup> The shield connection must be implemented on the motor side.

## Pin layout

8-pin M12 flange socket	Power supply				Serial data transmission				Other signals <sup>1)</sup>	
	<b>8</b>	<b>2</b>	<b>5</b>	<b>1</b>	<b>3</b>	<b>4</b>	<b>7</b>	<b>6</b>	/	/
	<b>13</b>	<b>11</b>	<b>14</b>	<b>12</b>	<b>7</b>	<b>8</b>	<b>9</b>	<b>10</b>	<b>5</b>	<b>6</b>
	-	-	<b>0V</b>	<b>U<sub>P</sub></b>	<b>RXP</b>	<b>RXN</b>	<b>TXP</b>	<b>TXN</b>	<b>T<sup>+</sup></b> <sup>2)</sup>	<b>T<sup>-</sup></b> <sup>2)</sup>
	Brown/ Green	Blue	White/ Green	White	Gray	Pink	Violet	Yellow	Brown	Green

<sup>1)</sup> Only with output cables inside the motor housing

<sup>2)</sup> Connections for an external temperature sensor; evaluation optimized for a KTY 84-130 (see *Temperature measurement in motors* in the *Encoders for Servo Drives* brochure)

**Cable shield** connected to housing; **U<sub>P</sub>** = Power supply voltage

**Sensor:** The sense line is connected in the encoder with the corresponding power supply line.

Vacant pins or wires must not be used!

**Output cables with a cable length > 0.5 m require strain relief for the cable.**

DRIVE-CLiQ is a registered trademark of SIEMENS AG.

## HEIDENHAIN

**DR. JOHANNES HEIDENHAIN GmbH**

Dr.-Johannes-Heidenhain-Straße 5

**83301 Traunreut, Germany**

☎ +49 8669 31-0

FAX +49 8669 32-5061

E-mail: info@heidenhain.de

[www.heidenhain.de](http://www.heidenhain.de)

This Product Information document supersedes all previous editions, which thereby become invalid. The basis for ordering from HEIDENHAIN is always the Product Information document edition valid when the order is made.



### Further information:

Comply with the requirements described in the following documents to ensure correct and intended operation:

- Brochure: *Encoders for Servo Drives* 208922-xx
- Brochure: *Interfaces of HEIDENHAIN Encoders* 1078628-xx
- Mounting Instructions: *ECN 1123S, EQN 1135S* 1254938-xx
- Brochure: *Cables and Connectors* 1206103-xx